

Temperature Analysis for the Point-Cell Source in the Vapor Deposition Process

Jongwook Choi*, **Sungcho Kim**

*School of Mechanical and Automotive Engineering,
Suncheon National University, Suncheon, Jeonnam, 540-742, Korea*

Hun Jung

*Graduate School, Department of Mechanical Engineering,
Chonnam National University, Gwangju, 500-757, Korea*

The information indicating device plays an important part in the information times. Recently, the classical CRT (Cathod Ray Tube) display is getting transferred to the LCD (Liquid Crystal Display) one which is a kind of the FPDs (Flat Panel Displays). The OLED (Organic Light Emitting Diodes) display of the FPDs has many advantages for the low power consumption, the luminescence in itself, the light weight, the thin thickness, the wide view angle, the fast response and so on as compared with the LCD one. The OLED has lately attracted considerable attention as the next generation device for the information indicators. And also it has already been applied for the outside panel of a mobile phone, and its demand will be gradually increased in the various fields. It is manufactured by the vapor deposition method in the vacuum state, and the uniformity of thin film on the substrate depends on the temperature distribution in the point-cell source. This paper describes the basic concepts that are obtained to design the point-cell source using the computational temperature analysis. The grids are generated using the module of AUTOHEXA in the ICEM CFD program and the temperature distributions are numerically obtained using the STAR-CD program. The temperature profiles are calculated for four cases, i.e., the charge rate for the source in the crucible, the ratio of diameter to height of the crucible, the ratio of interval to height of the heating bands, and the geometry modification for the basic crucible. As a result, the blowout phenomenon can be shown when the charge rate for the source increases. The temperature variation in the radial direction is decreased as the ratio of diameter to height is decreased and it is suggested that the thin film thickness can be uniformed. In case of using one heating band, the blowout can be shown as the higher temperature distribution in the center part of the source, and the clogging can appear in the top end of the crucible in the lower temperature. The phenomena of both the blowout and the clogging in the modified crucible with the nozzle-diffuser can be prevented because the temperature in the upper part of the crucible is higher than that of other parts and the temperature variation in the radial direction becomes small.

Key Words : OLED (Organic Light Emitting Diodes), Point-Cell Source, Radiative Heat Transfer, Conductive Heat Transfer, Vapor Deposition

* Corresponding Author,

E-mail : choijw99@postown.net

TEL : +82-61-750-3957; **FAX :** +82-61-753-3962

School of Mechanical and Automotive Engineering,
Suncheon National University, Suncheon, Jeonnam,
540-742, Korea. (Manuscript **Received** March 15, 2004;

Revised July 17, 2004)

1. Introduction

The display device for information indicating plays a major role in the information society. The CRT (Cathode Ray Tube) display has been

widely used, however, is getting transferred recently to the LCD (Liquid Crystal Display) display of FPDs (Flat Panel Displays). The LCD display requires the light from the back side because it does not emit light in itself. Also, the LCD display has the technical limits for the complicated manufacturing process, the response time, the brightness, the contrast, the view angle, the geometric scale, etc. The methods for overcoming them are being studied, and the OLED (Organic Light Emitting Diode) display are developed, which has the merits of the low-voltage drive, the luminescence in itself, the light weight, the thin thickness, the wide view angle, the fast response, and so on (Tang et al., 1989; Hamada et al., 1995; Tokito et al., 1995; Lee et al., 2001; Kang et al., 2001). The OLED display is evaluated as the next generation FPDs with high resolution and has already been used for the outside panel of a mobile phone. It can be applied to IMT-2000, PDA (Personal Digital Assistants), digital camera and camcorder, laptop computer, flat TV, etc.

Since the OLED had been found by Pope in 1963, the researches were started using the mono-molecular (Tang and VanSlyke, 1987) and the polymer (Burroughes et al., 1990). The OLED has been widely developed using the physical vapor deposition process in the vacuum state (Smith, 1994). It is composed of the thin film with multi-layers. The thin film thickness is only 1,000 Å. The OLED is highly efficient because it can be driven at low voltage of ten. The structure consists of the various components such as anode, HIL (Hole Injection Layer), HTL (Hole Transport Layer), EML (Emitting Layer), HBL (Hole Blocking Layer), ETL (Electron Transport Layer), EIL (Electron Injection Layer), and cathode (Hoffmann et al., 2003).

The OLED manufacturing is classified into the several processes; pre-treatment, evaporation, encapsulation, and quality control. The thin film is formed on the substrate in the high vacuum chamber of about 10^{-6} torr using the vapor deposition method, of which device consists of the source, crucible, film thickness monitor, metal shadow mask, glass substrate, power supply and

so on (Kim, 2003; Schwambera et al., 2003; Matsumoto et al., 2003). The source is the material with the high vapor pressure, and evaporated at about $200^{\circ}\text{C} \sim 300^{\circ}\text{C}$ by heating. The organic material in the form of atom or molecule is transported to the substrate, and the particles are deposited on the substrate, and then the film grows through the surface reaction. Here, the uniformity of thin film and the phenomena of both the clogging and the blowout depend on the temperature distribution in the point-cell source. The clogging means that the source is evaporated and deposited at the exit of the crucible with lower temperature than the evaporation one, and the evaporated source clogs the exit of the crucible. The blowout means that the source is earlier evaporated in the inner part than the outer one. The vapor deposition process cannot be progressed like the clogging and the blowout.

In this research, the temperature distributions are obtained in the point-cell source used for the substrate of $370\text{ mm} \times 470\text{ mm}$. The temperature is analyzed for four cases, that is, the charge rate for the source in the crucible, the ratio of diameter to height of the crucible, the ratio of interval to height of the heating bands, and the modified shapes for the basic crucible. The grids are generated using the module of AUTOHEXA in the ICEM CFD program (ICEM CFD Reference Manual, 2000) and the temperature distributions are obtained using the STAR-CD program (STAR-CD User Guide, 2001). The temperature distributions of the crucible and the source due to the heating bands are obtained by calculating the radiative heat transfer (Park and Kim, 2002) in the fluid region and the conductive heat transfer (Park, 1991) in the solid regions, respectively. The steady 3-dimensional energy equation is solved to analyze the temperature.

2. Design of the Point-Cell Source

The vapor deposition process for manufacturing the OLED in the vacuum chamber is drawn in Fig. 1. The point-cell source is composed of the source, the crucible, the upper and the lower heating bands. The deposition rate

can be controlled by the upper heating band, and the source can be preheated by the lower heating one. The source is sublimated at about 200°C ~ 300°C and deposited on the rotating substrate of relatively low temperature in the form of atom or molecule, and the particles are rearranged by the bonding strength. The source is evaporated by the cosine distribution (Smith, 1994), however, the cosine function is not used in the paper. The point-cell source is designed in Fig. 2. The diameter, height, thickness of the crucible are 4 cm, 10 cm, 0.3 cm, respectively. The charge rate for the source in the crucible is 75%, and the real capacity of the crucible is 94 cm³.

The configurations of the point-cell source are newly designed for four cases using the CAD module of AUTOHEXA in the ICFM CFD program. The geometric dimensions are given in

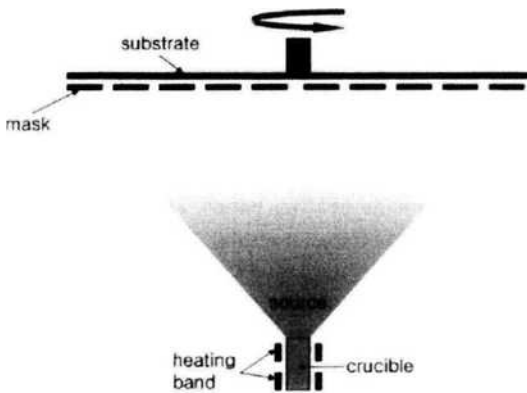

Fig. 1 The point-cell source in the vacuum chamber

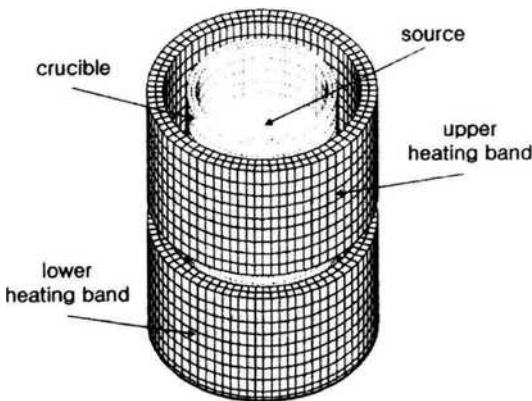

Fig. 2 The configuration of the point-cell source

Fig. 3. The case I is designed with the charge rate ($s/h \times 100$) for the source in the crucible. The charge rates are 25%, 50%, 75%, and 100%, respectively. The case II is designed with the ratio (d/h) of diameter to height of the crucible. The ratios of diameter to height are 0.2, 0.3, 0.4, 0.5, and 0.6, respectively. The case III is designed with the ratio (a/b) of gap to height of the heating bands, and they are 0.0, 0.2, 0.5, 0.9, 1.4, and 2.0, respectively. The case IV is designed with modifying the basic crucible as arranged in Fig. 4, where the basic type, the modified type I, II are suggested, respectively. Figure 5 shows the point-cell source of the basic type with 75% for the charge rate, 0.4 for the ratio of diameter to height, and 0.2 for the ratio of interval to height, respectively.

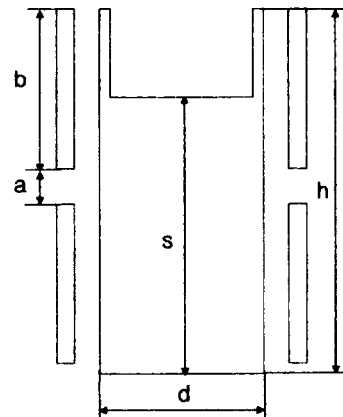

Fig. 3 The variables for configuration (Case I-Case III)

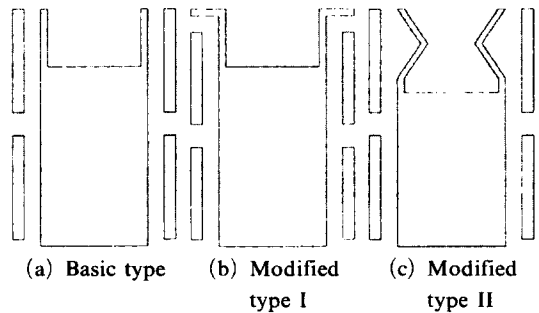

Fig. 4 The modified types for the basic crucible (Case IV)

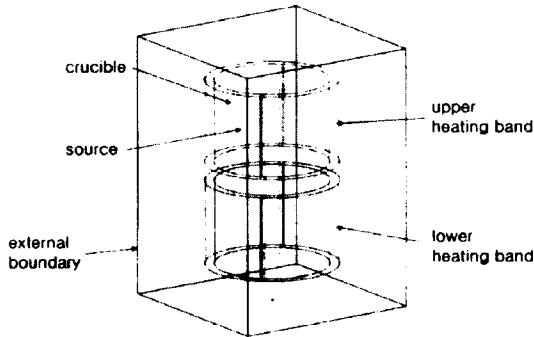

Fig. 5 The configuration of the point-cell source for the temperature analysis

3. Grid Generation and Computational Conditions

The grids for the configurations of the point-cell source are generated using the module of AUTOHEXA in the ICEM CFD program. The module generates automatically the grids in a hexa type. Its quality is higher as compared with that done by the module of AUTOTETRA. However, it is difficult to apply the module of AUTOHEXA to the complicated configuration. The grids for the point-cell source are plotted in Fig. 6. The grid and node points in number are 63,040 and 68,157, respectively. The point-cell source can be classified in one fluid region and two solid ones to analyze the temperature. The radiative heat is generated by the heating bands in the fluid region, and the conductive heat is supplied in both the crucible and the source of the solid ones. There is no necessity for generating the grids in the heating band. The overlapping grids should be removed between the crucible and the source for the purpose of the successful computation. The boundary conditions are also embedded in Fig. 6. The temperature values are set to 575K and 473K in the upper and the lower heating bands, respectively. The boundary conditions of the heat conduction are given in the crucible and the source. The external boundary isn't the real configuration, however, it is necessary to obtain the temperature distribution on it. If the real configuration of the vacuum chamber is used, the great number of grids is required. The

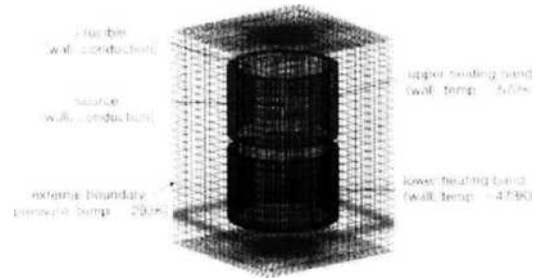

Fig. 6 The grids and the boundary conditions in the computational domain

computational model for the point-cell source is made to be simplified because the trend of temperature distribution in the source is important. The external boundaries are fixed to 293K and the pressure condition (STAR-CD User Guide, 2001). The wall conditions are applied on the other boundaries. The initial temperature condition is constant by 293K and the steady temperature distributions are obtained for the 3-dimensional point-cell source.

4. Temperature Analysis

The temperature distributions are obtained for the point-cell source using the STAR-CD program. The energy equation is solved for the 3-dimensional models at the steady state. The implicit method is utilized in the numerical algorithm. As mentioned above, the grid data obtained from the ICEM CFD program are ready to be used in the STAR-CD one for the temperature analysis. The flow is quiescent, i.e., its velocity is set to 0 m/s, and the heat conductivity is taken as a very small value in the fluid region, because only the radiative heat transfer is considered in the vacuum state. The density, the specific heat, and the conductivity in the fluid region are set to 1.205 kg/m³, 1,006 J/kgK, and 1.0×10^{-7} W/mK, respectively. These physical properties of the crucible in the solid regions are assigned to 3,960 kg/m³, 850 J/kgK, and 30 W/mK, respectively. And also their values of the source in the solid regions are fixed to 105 kg/m³, 1,400 J/kgK, and 0.35 W/mK, respectively. The physical setup for the patches and the beams is re-

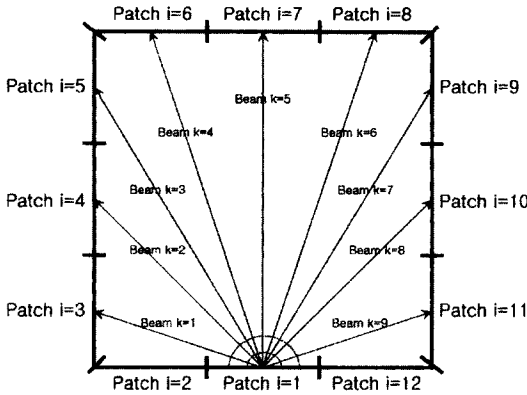

Fig. 7 The definitions of the patch and the beam

quired for analyzing the radiative heat transfer (Özişik, 1985). The beams radiate on the patches as shown in Fig. 7, and the patches are coincident with the meshes. The numbers of patches and beams per patch are 11,480 and 10,000, respectively. The view factor F_{ij} between patches i and j is the fraction of the total radiation leaving surface i which is intercepted by j , and the equation can be given as $F_{ij} = \sum_{k=1}^{N_{L,i}} \alpha_k f_{ij}$. Here, $N_{L,i}$ is the total number of beams for the patch i , the coefficient α_k is equal to 1 if the beam strikes j or zero otherwise. The value of f_{ij} is the view factor for a single beam emanating from the centroid of a patch, and deduced from the intercepted area by an unit hemisphere (STAR-CD Methodology, 2001).

5. Results and Discussion

The temperature distributions in the point-cell source and on the upper face of the source are calculated for four cases. The temperature distribution of the upper face of the source is important because the uniformity of thin film depends on the temperature distribution in the vapor deposition process in the vacuum state.

5.1 Temperature analysis with the charge rate (Case I)

Figure 8 shows that the temperature distributions with the charge rate of the source in the crucible. They are obtained for the charge rate

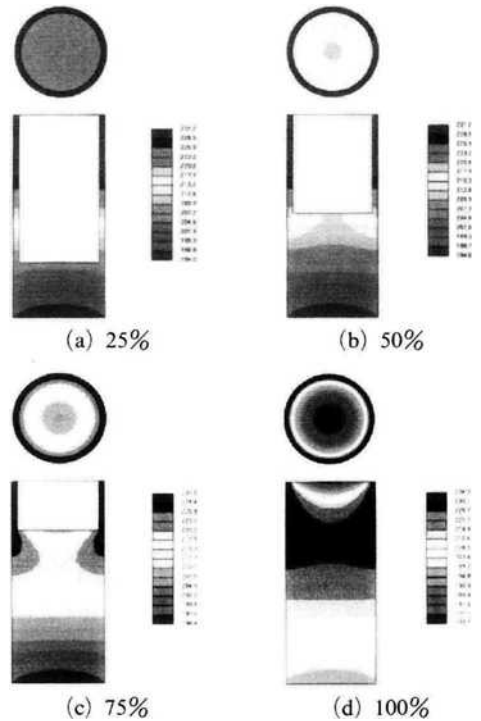

Fig. 8 The temperature distributions with the charge rate

of 25%, 50%, 75%, and 100%, respectively. The value of temperature increases gradually in the normal direction at the charge rate of 25% and the 50%. The source is sublimated stably at these temperature distributions because the upper part of the source is evaporated first. However, The value of temperature in the middle part of the source is higher than that in the upper part of the source at the charge rate of 75% and 100%. In these cases, the blowout can be shown up because the source in the middle part can be sublimated earlier as compared with the upper part of the source. The vapor deposition process can last for a long time with increasing the charge rate, however, the blowout can appear.

The uniformity of the thin film on the substrate depends on the temperature variation in the radial direction on the upper face of the source. The point-cell source should be designed to maintain an uniform temperature in the radial direction to get the uniform thin film. The temperature on the upper face of the source with

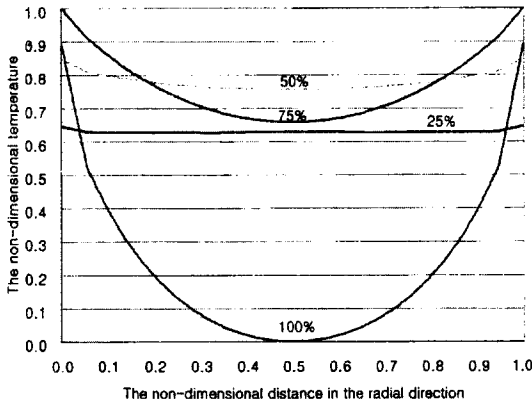

Fig. 9 The temperature variations on the upper face of the source with the charge rate

the charge rate are plotted in Fig. 9. The temperature in the radial direction increases with increasing the charge rate. The 25% charge rate is a good condition to maintain the uniformity of thin film because the temperature is almost constant in the radial direction. But, the vapor deposition process cannot continue long because the charge rate is small. On the other hand, the uniform thin film cannot be confirmed at the 100 % charge rate because the temperature is large in the radial direction.

5.2 Temperature analysis with the ratio of diameter to height (Case II)

The temperature distribution plays an important part in designing the diameter and height of the crucible. The temperature distributions with the ratio of diameter to height of the crucible are described in Fig. 10. They are obtained for the ratios of diameter to height of 0.2, 0.3, 0.4, 0.5, and 0.6, respectively. And, the charge rate of the source is 75%. The temperature increases gradually in the normal direction at the ratio of 0.2. The temperature of the middle part of the source gradually increases as compared with other parts with increasing the ratio of diameter to height. Figure 11 describes the temperature on the upper face of the source with the ratio of diameter to height. The temperature increases in proportion to the ratio of diameter to height. That is, the variation of temperature decreases in the radial direction with decreasing the crucible diameter.

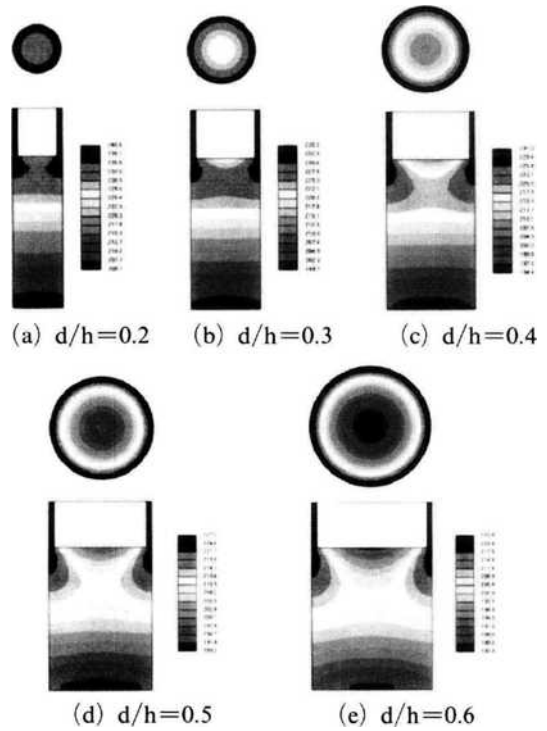

Fig. 10 The temperature distributions with the ratio of diameter to height of the crucible

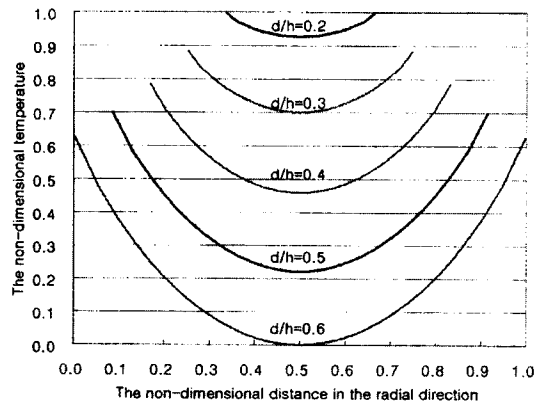

Fig. 11 The temperature variations on the upper face of the source with ratio of diameter to height of the crucible

5.3 Temperature analysis with the ratio of interval to height of the heating bands (Case III)

The temperature distributions are produced in Fig. 12 with the ratio of the interval between heating bands to the height of heating band.

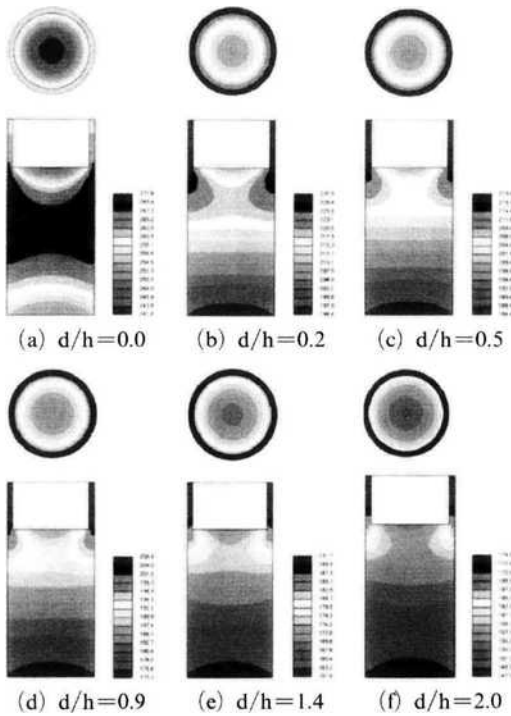

Fig. 12 The temperature distributions with ratio of interval to height of the heating bands

Here, the ratios are 0.0, 0.2, 0.5, 0.9, 1.4, and 2.0, respectively. The ratio of 0.0 stands for just one heating band. In this case, the blowout can be shown up because the temperature is higher as compared with other parts at the middle part of the source, and the clogging can appear because the sublimated source can be deposited on the upper part of the crucible in the lower temperature as compared with the sublimation temperature. The heating band should be divided into the upper and lower parts, and the temperature of the upper heating band should be higher than that of the lower heating band. There is a little difference in the tendency of the temperature distributions with increasing the ratio. However, the temperature decreases with increasing the ratio since the heat capacity decreases.

The temperature in the radial direction on the upper face of the source are shown in Fig. 13. The temperature variation is little difference according to the ratio. The upper heating band plays a major role in maintaining the high temperature

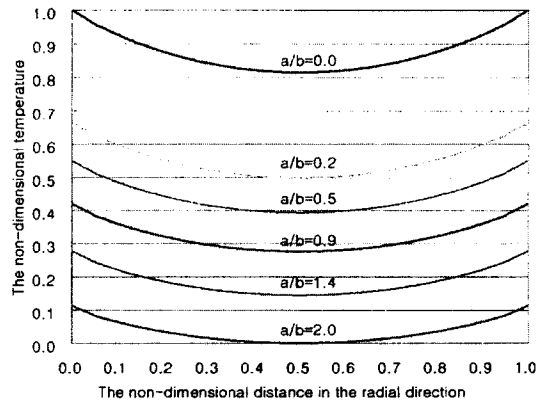

Fig. 13 The temperature variations on the upper face of the source with ratio of interval to height of the heating bands

on the upper part of the crucible. It is necessary to maintain the proper interval because the deposition rate is controlled by the upper heating band, and the source is preheated by the lower heating one.

5.4 Temperature analysis with the various crucibles (Case IV)

The various crucibles has been used in the vapor deposition device. However, the crucibles has been manufactured by experience in disregard of the temperature analysis for the point-cell source. The temperature distributions are obtained for the modified type I and II on the basis of the basic type in Fig. 14. In the modified type I, the circular band is attached to the upper side of the basic type crucible, and the clogging can be come out because the temperature of the circular band is lower than that of other parts. The radiant energy from the crucible becomes larger than the incident energy by the heating bands. The variation of temperature is higher than that of the basic type in the radial direction on the upper face of the source as depicted in Fig. 15. In the modified type II, the nozzle-diffuser is attached to the upper face of the basic type crucible. The blowout and the clogging can be suppressed because the temperature in the upper side of the crucible is higher than that in other parts (Fig. 14), and the temperature variation in the radial direction reduces to be small

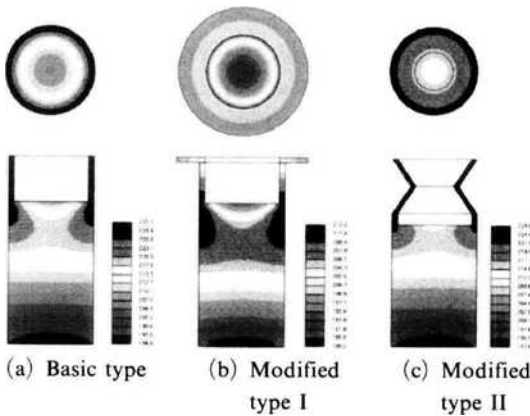

Fig. 14 The temperature distributions with the various crucibles

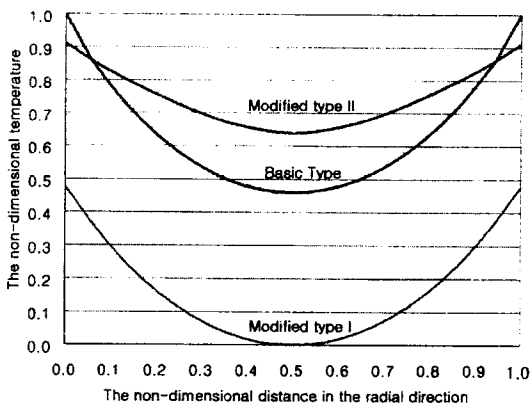

Fig. 15 The temperature variations on the upper face of the source with the various crucibles

as drawn in Fig. 15. The radiant energy from the source is also small since the crucible has a narrow exit. Thus, the modified type II has a favorable condition for the temperature distribution.

6. Conclusion

The CRT display is getting transferred to the LCD one because of its convenience. The OLED display has lately attracted considerable attention as the next generation device for information indicating. The OLED has already been used for the outside panel of a mobile phone. It can be applied to other fields. The vapor deposition device for manufacturing the OLED should be

designed efficiently and precisely with the temperature analysis. However, the point-cell source has been designed without this analysis until now and so the related researches have not been almost surveyed. In this paper, the basic concepts are obtained and proposed for designing the point-cell source using the temperature analysis, and the temperature distributions are numerically calculated for four selected cases.

In the temperature analysis with the charge rate of the source, the blowout can be shown up because the temperature at the middle of the source increases with increasing the charge rate. The thin film on the substrate can be deposited non-uniformly at the high charge rate since the temperature variation in the radial direction increases in proportion to the charge rate. In general, the charge rate of 70% has been used in manufacturing the substrate of the OLED to prevent these phenomena.

In the temperature analysis with the ratio of diameter to height of the crucible, there is a little difference in the trend of temperature distributions, however, the temperature variation in the radial direction increase with increasing the ratio.

In the temperature analysis with the ratio of interval to height of the heating bands, the blowout can turn up if one heating band is adopted because the temperature in the middle part of the source is higher than that of the upper part. It is found that there is a little difference in the temperature distributions if the ratio increases. However, the deposition rate is hard to control due to the temperature decrease in the lower part of the source when the ratio increases. Here, the temperature variation in the radial direction are a little different.

In the temperature analysis with the various crucibles, the clogging can be shown up in the modified type I, however, the blowout and the clogging can be suppressed in the modified type II. Finally, the point-cell source with the exit of the nozzle-diffuser type, the small diameter, and the low charge rate has good conditions in the view of the temperature distributions. These methods and results on the temperature analysis in

the point-cell source can be utilized for manufacturing the vacuumed deposition device.

Acknowledgment

This work was supported by grant No. R08-2003-000-10487-0 from the Basic Research Program of the Korea Science & Engineering Foundation.

References

- Burroughes, J. H., Bradley, D. D. C., Brown, A. R., Marks, R.N., Maackay, K., Friend, R. H., Burns, P. L. and Holmes, A. B., 1990, "Light-Emitting Diodes Based on Conjugated Polymers," *Nature*, Vol. 347, pp. 539~541.
- Hamada, Y., Sano, T., Shibata, K. and Kuroki, K., 1995, "Influence of the Emission Site on the Running Durability of Organic Electroluminescent Devices," *Japanese Journal of Applied Physics*, Vol. 34, pp. L824~L826.
- Hoffmann, U., Netuschil, P., Bender, M., and Sauer, P., 2003, "OLED Manufacturing Using Vertical In-Line Machine Concept," *Society for Information Display 03 DIGEST*, pp. 1410~1413.
- ICEM CFD Reference Manual (version 4.2)*, 2000, ICEM Engineering.
- Kang, G. W., Ahn, Y. J. and Lee, C. H., 2001, "Effects of Doping in Organic Electroluminescent Devices Doped with a Fluorescent Dye," *Journal of Information Display*, Vol. 2, No. 3, pp. 1~5.
- Kim, S. W., 2003, "Next Generation Mass Production Line and its OLED Module," *Society for Information Display 03 DIGEST*, pp. 1414~1417.
- Lee., S. S., Song, T. J., Ko, M. S. and Cho, S. M., 2001, "Low-Molecular-Weight White Organic-Light-Emitting-Devices using Direct Color Mixing Method," *Journal of Information Display*, Vol. 2, No. 3, pp. 6~12.
- Matsumoto, E., Maki, S., Yanagi, Y., Nishimori, T., Kondo, Y., Kishi, Y. and Kido, J., 2003, "The High Deposition Rate and High Material Yield Evaporation Method for OLED Layers," *Society for Information Display 03 DIGEST*, pp. 1422~1425.
- Özişik, M. N., 1985, *Heat Transfer*, McGraw-Hill, pp. 593~701.
- Park, S. I., 1991, "Heat Transfer in Countercurrent Gas-Solid Flow inside the Vertical Pipes," *KSME International Journal*, Vol. 5, No. 2, pp. 125~129.
- Park, W. H. and Kim, T. K., 2002, "Narrow Band Radiative Solutions within a Cubical Enclosure Filled with Real Gas Mixtures," *KSME International Journal*, Vol. 16, No. 2, pp. 861~869.
- Schwambara, M., Meyer, N., Gersdorff, M. and Reinhold, M., 2003, "OLED Manufacturing by Organic Vapor Phase Deposition," *Society for Information Display 03 DIGEST*, pp. 1419~1421.
- Smith, D. L., 1994, *Thin-Film Deposition Principles and Practice*, McGraw-Hill, pp. 63~118.
- STAR-CD Methodology (version 3.15)*, 2001, Computational Dynamics Limited.
- STAR-CD User Guide (version 3.15)*, 2001, Computational Dynamics Limited.
- Tang, C. W. and VanSlyke, S. A., 1987, "Organic Electroluminescent Diodes," *Applied Physics Letter*, Vol. 51, No. 12, pp. 913~915.
- Tang, C. W., VanSlyke, S. A. and Chen, C. H., 1989, "Electroluminescence of Doped Organic Thin Films," *Journal of Applied Physics*, Vol. 65, No. 9, pp. 3610~3616.
- Tokito, S., Takata, J. and Taga, Y., 1995, "Organic/Inorganic Superlattices with Ordered Organic Layers," *Journal of Applied Physics*, Vol. 77, No. 5, pp. 1985~1989.